



PRODUCT CATALOG

Valves & Fittings for the HVAC/R technician



part of ASPEN PUMPS GROUP



A US manufacturer of valves and fittings, C&D is a well-established business with a strong reputation in the HVAC/R sector. Established in 1967 in Oklahoma City, C&D continues to offer unrivalled product quality and service.

Acquired in 2023 by Aspen Pumps Group, a leading global manufacturer of air conditioning and refrigeration aftermarket products, C&D marks an important step in Aspen's US manufacturing and sales capabilities.

Investment in the C&D proposition is highlighted this year with an expanded and innovative product offer. Many of the products surpass current US market requirements, all of which are supported by a blue-chip national customer base and an established national sales network.

Thank you for your interest in our products
for further information please get in touch...



800-654-9233



800-840-0443



sales@cdvalve.com



201 NW 67th St, Oklahoma City OK 73116

Contents



LINE SERVICE VALVES

T-36 Series Premium Line Service Valve	4
36 LP Standard & Economy Line Service Valve	5

SERVICE VALVES

M Series copper-to-copper Braze-on Service Valves	6
Brass-to-brass Braze-on Service Valves	6
B-Series Clamp-on Service Valves	7

VALVES

Reversing Valves	8
Reversing Valve Coils	8
Rotalock Valve Solder	9
Rotalock Valve Flare	9
Capped Line Valve	10

TEES & CONNECTORS

84 TS Series Standard & Economy	11
Forged Access Tees	12
Tee Connections	12
Rotalock Straight Connector	13
Rotalock Elbow Connector	13
Brass Access Bodies	14

CORE TOOLS

BV-CRT Ball Valve Core Removal Tools	15
Core Removal Tools	16
Thermometer (Core Removal Tool Accessory)	17
Braze in Service Valves (Core Removal Tool Accessory)	17
Core Depressors	18
Hose-End Ball Valve	18

KITS

Superheat Kits	19
Service Kits	19

COUPLERS & AUTOMOTIVE

Sure Seal™ Retaining Couplers	20
Adapters / Couplers & Automotive	21

VALVE ANCILLARIES

Blower Wheel Pullers	22
Fastap Tube Piercing Pliers	22
Locking Caps and Keys	23
Oil Tap & Cap Tubes	24
Parts, O-Rings and Replacement Parts	25-26
Vibration Eliminator	27
Rotalok Teflon Gasket	27

C&D Valve manufactures custom components and assemblies for both OEM and after-market applications. Let us know what you need regardless of the volume and we'll see what we can do for you.

T-36 Series Premium Line Service Valves



The T 36 Series comes with a CD2250 wrench cap, CD4460 valve core and is available in a variety of tube sizes. There are 1/8" male pipe threads below the hex. Material is CDA 360 brass and standard refrigeration tubing.

KEY FEATURES

- The wrench cap is standard
- 1/8" pipe thread below the hex is standard on all but the CD3456—allows securing to a bulkhead with a lock nut
- Extra bushings included with several items to provide a choice on size of hole to cut at the job and reduce the amount of inventory to be maintained

Part No.	BAG QTY	Description
CD3434	6	3/16" copper tubing, 1/8" copper bushing, wrench cap and core
CD3436	6	1/4" copper tubing, 3/16" copper bushing, wrench cap and core
CD3456	6	5/16" copper tubing, 1/4" copper bushing, wrench cap and core
CD3602	6	1/4" copper tubing, 3/16" and 1/8" copper bushings, wrench cap and core
CD3603	6	3/16" copper tubing, wrench cap and core
CD3604	6	1/4" copper tubing, wrench cap and core
CD3608	6	1/8" copper tubing, wrench cap and core
CD3600	6	1/8" ID, 3/16", 1/4", 5/16" steps 1/8" MPT below hex wrench cap and core
CD3688	25	Used with T36 Series, 2 lock nuts included with packaged access valves

CD3600 valve can be adapted to serve you in the following ways:

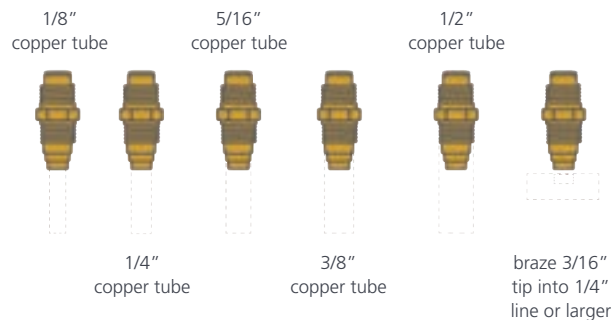



36 LP Series Standard & Economy Line Service Valves

The 36LP Series comes with a CD2250 wrench cap and CD4460 valve core and is available in a variety of tube sizes ranging from 1/8" to 3/8". There are no pipe threads. Material is CDA 360 brass and standard refrigeration tubing. Tube length is approximately 2".

INSTRUCTIONS

1. Remove cap and core
2. Insert tubing or body into the corresponding size line or hole and braze into place
3. Replace core, tighten, evacuate and charge system
4. Replace cap

Part No.	BAG QTY	Description	
CD1010	6	1/8" copper tubing, wrench cap and core	
CD1212	6	3/16" copper tubing, wrench cap and core	
CD2525	6	1/4" copper tubing, wrench cap and core	
CD3605	6	5/16" copper tubing, wrench cap and core	
CD3606	6	3/8" copper tubing, wrench cap and core	
CD3619	6	1/8" ID, 3/16", 1/4", 5/16" steps, wrench cap and core	

Part No.	BAG QTY	Description	
CD8408	6	1/8" copper tubing, cap and core	
CD8403	6	3/16" copper tubing, wrench cap and core	
CD8404	6	1/4" copper tubing, cap and core	
CD8405	6	5/16" copper tubing, cap and core	
CD8406	6	3/8" copper tubing, cap and core	
CD8400	6	1/8" ID, 3/16", 1/4", 5/16" steps, cap and core	



Copper-to-Copper M Series Braze-on Service Valves

The M Series is the first and best braze-on, self-piercing copper saddle valve. It is widely used and easily installed on a charged line. After brazing the saddle portion onto line, the steel pin with valve core penetrates the line and is locked into place simply by tightening the cap. Available in sizes ranging from 1/4" to 1-1/8".

INSTRUCTIONS

1. Prepare line and clean tube. Remove cap and pin. Flux or solder paste saddle and install on line. Heat and braze copper saddle.
2. Let cool and pressure test braze, if desired. Insert pin with PTFE o-ring into body. Put on cap and tighten with wrench on body to avoid breaking braze joint. As cap is tightened, steel pin penetrates tubing.
3. Last turn crimps brass edge over top of pin for secure fit and forming flared end. Remove cap, and fitting is ready to use. If complete penetration is not made, put cap back on and tighten further.
4. When work is complete, replace cap, wrench tight for permanent use or install new cap with neoprene o-ring, thumb tight.

Part No.	BAG QTY	Description	
CD5512	4	Copper saddle for 1/2" line	
CD5518	2	Copper saddle for 1-1/8" line	
CD5534	2	Copper saddle for 3/4" line	
CD5516	6	Copper saddle for 5/16" line	
CD5558	3	Copper saddle for 5/8" line	
CD5578	3	Copper saddle for 7/8" line	
CD5514	6	Copper saddle for 1/4" line	
CD5538	6	Copper saddle for 3/8" line	

Brass-to-Brass Bot Stinger Braze-on Service Valves

- Valve core and cap
- Plated steel body – CDA 360 brass saddle
- Four-way seal between body and saddle

INSTALLATION INSTRUCTIONS

1. Press saddle onto line firmly (use pliers)
2. Apply flux and braze to line
3. Allow to cool
4. Screw body with core into saddle
5. Evacuate and charge system
6. Replace cap

Brass-to-Brass Bot Stinger		
Part No.	BAG QTY	Description
CD2814	6	Brass saddle for 1/4" line
CD2816	6	Brass saddle for 5/16" line
CD2838	6	Brass saddle for 3/8" line
CD2812	4	Brass saddle for 1/2" line
CD2834	2	Brass saddle for 3/4" line
CD2878	2	Brass saddle for 7/8" line
CD2818	2	Brass saddle for 1-1/8" line

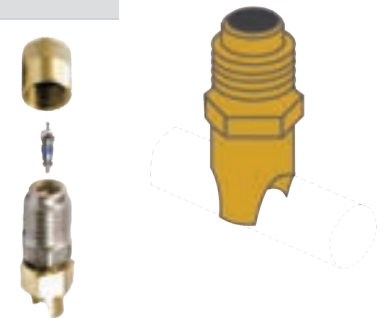

B Series Clamp-on Service Valves





KEY FEATURES

A line tap valve that is easy to use. Five individual sizes for special access jobs. Viton® gasket for heat extremes.

Part No.	BAG QTY	Description
CD2140	2	For 1/4" (6 mm) lines
CD2160	2	For 5/16" (8 mm) lines
CD2380	2	For 3/8" (10 mm) lines
CD2120	2	For 1/2" (12 mm) lines
CD2580	2	For 5/8" (16 mm) lines



- 

1. Place aluminum channel on line. Insert aluminum slide into grooves on channel
- 

2. Grip slide and channel with pliers. Place steel pin in body and screw into place
- 

3. Holding grip on channel and slides, tighten steel housing – Unique torque action provides permanent clamp
- 

4. Continue to tighten steel housing – Neoprene gasket on pin gives long-life seal

STANDARD LINE TAP VALVE

The CD4338 and CD4358 line tap valves pierce with a needle which automatically retracts and back seats when work is complete. The refrigerant line remains free of any restriction. No special installation tools are needed because socket head screws and hex wrench are included with every valve. These dependable and field-proven valves are easy to install and suitable with all refrigerants.

Part No.	BAG QTY	Description
CD4358	1	Fits 1/2" (12 mm) and 5/8" (16 mm) tubes
CD4338	1	Fits 1/4" (6 mm), 5/16" (8 mm) and 3/8" (10 mm) tubes



TECH TIP

Clamp-on line tap valves are a quick and economical way to temporarily access a refrigerant system. After using line tap valves, installing a permanent access tee is recommended.

Reversing Valves

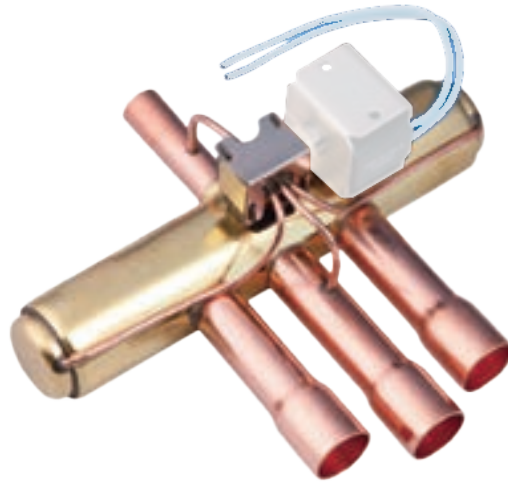

Part No.	Reversing Valves
RV-02T5638	2 ton 5/16" & 3/8"
RV-02T1238	2 ton 1/2" & 3/8"
RV-02T3858	2 ton 3/8" & 5/8"
RV-03T5818	3 ton 5/8" & 1/2"
RV-06T3412	6 ton 3/4" & 1/2"
RV-06T7812	6 ton, 7/8" & 1/2"
RV-07T5878	7 ton 5/8" & 7/8"
RV-10T7834	10 ton 7/8" & 3/4"
RV-10T1834	10 ton 1 1/8" & 3/4"
RV-10T1878	10 ton 1 1/8" & 7/8"
RV-12T1838	12 ton 1 1/8 x 1 3/8"

C&D Reversing Valves have been developed and tested as drop-in replacements for OEM equipment and are compatible with most common refrigerants and lubricants, including the higher-pressure refrigerants such as a R-410a and R-32.

- Safe working pressure: 650 psig
- Ambient operating temperature: -22°F to 250°F
- Work fluid temperature: -22°F to 122°F
- Coils available in multiple voltages, lead-wire or spade connections
- Certification: UL and CSA

Reversing Valve Coils 24V AC and 120V AC Lead-wire and spade terminal

Part No.	Description
LW-24V	Lead wire coil 24V AC
RVC-24V	Coil 24V AC Spade Connection
LW-120V	Lead wire coil 120V AC
RVC-120V	Coil 120V AC Spade Connection



Rotalock Solder Valve



NEW

C&D Rotalock valves offer unsurpassed reliability, flow rate and corrosion resistance. Manufactured from carbon steel with a stainless-steel spindle and 100% copper connector they are first zinc plated and then tin plated.

- High flow port design offering lower pressure drops.
- Double plated for the ultimate in corrosion resistance.
- Available in single and double access port configurations. (Single is standard)
- 100% copper connector on solder models.
- OEM customization available.
- Safe working pressure: 650psig
- Packed with a Teflon gasket.
- Certification: UL

Part No.	Description
RL-RCV-1434	Rotalock Valve 1/4 ID x 3/4 R/L Nut
RL-RCV-3858	Rotalock Valve 3/8 ID x 5/8 R/L Nut
RL-RCV-3834	Rotalock Valve 3/8 ID x 3/4 R/L Nut
RL-RCV-1201	Rotalock Valve 1/2 ID x 2 R/L Nut
RL-RCV-5801	Rotalock Valve 5/8 ID x 1 R/L Nut
RL-RCV-5814	Rotalock Valve 5/8 ID x 1/4 R/L Nut
RL-RCV-7814	Rotalock Valve 7/8 ID x 1/4 R/L Nut
RL-RCV-1814	Rotalock Valve 1 1/8 ID x 1 1/4 R/L Nut
RL-RCV-1834	Rotalock Valve 1 1/8 ID x 1 3/4 R/L Nut
RL-RCV-1384	Rotalock Valve 1 3/8 ID x 1 3/4 R/L Nut
RL-RCV-5834	Rotalock Valve 1 5/8 ID x 1 3/4 R/L Nut
RL-RCV-5824	Rotalock Valve 1 5/8 ID x 2 1/4 R/L Nut

Rotalock Valve Flare

Part No.	Description
RL-MF-1434	Rotalock Valve 1/4 Flare x 3/4 R/L
RL-MF-3834-NA	Rotalock Valve 3/8 Flare x 3/4 R/L Nut- No Access
RL-MF-3834	Rotalock Valve 3/8 Flare x 3/4 R/L Nut
RL-MF-1201	Rotalock Valve 1/2 Flare x 1 R/L Nut



NEW

Capped Line Valve

C&D Line valves offer unsurpassed reliability and corrosion resistance. Manufactured from carbon steel with a stainless-steel spindle and 100% copper connector they are first zinc plated and then tin plated.

- Double plated for the ultimate in corrosion resistance.
- Access port fitted with Schrader valve.
- Safe working pressure: 650psig
- OEM customization available.
- Certification: UL

Part No.	Description
RL-CLV-14	Double plated steel Capped Line Valve c/w Access - 1/4 ID
RL-CLV-38	Double plated steel Capped Line Valve c/w Access - 3/8 ID
RL-CLV-12	Double plated steel Capped Line Valve c/w Access - 1/2 ID
RL-CLV-58	Double plated steel Capped Line Valve c/w Access - 5/8 ID
RL-CLV-78	Capped Line Valve c/w Access - 7/8 ID..



84 TS Series Copper Access Tees

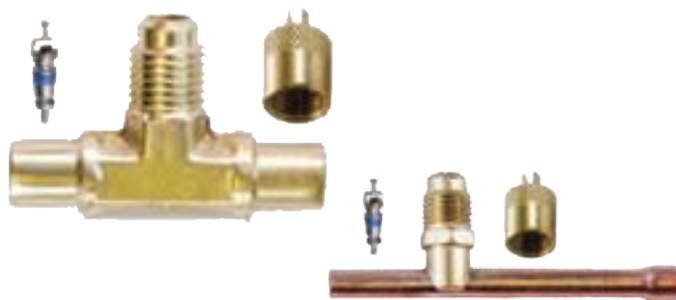

The 84 TS Series offers two styles of copper access tees in tubing sizes 1/4" to 1-1/8". Copper Tees allow connection at each end and require less solder than silver solder, such as 95-5.

Copper Tees are preferable where two line ends have not yet been attached or where it is desirable to cut a line rather than drive a hole in an uncharged system. Copper Tees can save time and money.

Tees with "CD" part numbers come with CD2250 wrench cap. Change "CD" to "CC" to substitute CD2245 standard brass cap.

INSTRUCTIONS

1. Remove cap and valve core
2. Clean tubing and apply flux
3. Insert tubing into each end and braze into place
4. Replace valve core, tighten, evacuate and charge system
5. Install cap when work is complete

Part No.	BAG QTY	Description	
CD8414	2	For 1/4" copper tube	
CD8416	2	For 5/16" copper tube	
CD8438	2	For 3/8" copper tube	
CD8412	2	For 1/2" copper tube	
CD8458	2	For 5/8" copper tube	
CD8434	2	For 3/4" copper tube	
CD8478	2	For 7/8" copper tube	
CD8420	2	1/4" x 3" tube, expanded to 1/4" ID on one end	
CD8425	2	5/16" x 3" tube, expanded to 5/16" on one end	
CD8426	2	3/8" x 3" tube, expanded to 3/8" ID on one end	

Part No.	BAG QTY	Description	
CD8427	2	1/2" x 3" tube, expanded to 1/2" ID on one end	
CD8428	1	5/8" x 3" tube, expanded to 5/8" ID on one end	
CD8429	1	3/4" x 3" tube, expanded to 3/4" ID on one end	
CD8431	1	7/8" x 3" tube, expanded to 3/4" ID on one end	

Part No.	BAG QTY	Description	
CD5421	2	5/16" x 2" refrigeration tube	
CD8505	2	5/16" ID and 3/8" OD	
CD8506	2	3/8" ID and 1/2" OD	

1/4" ID and 5/16" OD
will service 1/4", 5/16", 3/8"

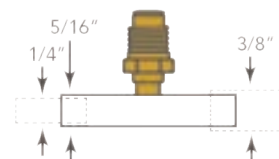

Tee Connections

KEY FEATURES

All brass and copper tees come in several different configurations with regard to valve cores, caps and valve depressors. C&D Customer Service can help you find the right tee for the right application.



Part No.	BAG QTY	Description
CD9601	2	1/4" male flare x 1/4" flare nut with depressor tip x 1/4" male flare on the branch with one valve core
CD9602	2	1/4" male flare with valve core x 1/4" male flare x 1/4" female flare nut with depressor tip on the branch
CD9603	2	All brass 1/4" female flare nut with valve core x 1/4" female flare nut with depressor tip on the branch
CD9606	2	1/4" male flare access x 1/4" male flare nut with depressor tip on the branch, cap and valve core included
CD9611	2	Forged brass tee, 1/4" female flare nut with depressor tip x 1/4" male flare access x 1/4" male flare access x 1/4" male flare access on branch with one valve core
CD9621	2	Same as CD9601 but without depressor tip
CD9622	2	Same as CD9602 but without depressor tip
CD9623	2	1/4" male flare x 1/4" male flare with two valve cores but no caps
CD9627	2	Same as CD9603 but without depressor tip
CD9628	2	Same as CD9611 but without depressor tip

Forged Access Tees

Part No.	PKG QTY	Description
CD9614	2	Forged brass tee, 1/4" MPT x 1/4" male flare x 1/4" male flare on branch, one cap and valve core
CD9616	2	Forged brass tee, 1/4" male flare x 1/8" MPT x 1/4" male flare on branch, one cap and valve core
CD9620	2	Forged brass tee, 1/4" male flare x 1/4" male flare x 1/8" MPT on branch, one cap and valve core

All 1/4" Flares are threaded for valve cores

NEW

Rotalock Straight Connector

Part No.	Description
RL-SC-1401	Rotalock Straight Connector - 1/4 ID x 1 R/L Nut
RL-SC-3834	Rotalock Straight Connector - 3/8 ID x 3/4 R/L Nut
RL-SC-1201	Rotalock straight connector - 1/2 ID x 1 R/L Nut
RL-SC-5801	Rotalock Straight Connector - 5/8 ID x 1 R/L Nut
RL-SC-7801	Rotalock Straight Connector - 7/8 ID x 1 R/L Nut
RL-SC-7814	Rotalock Straight Connector - 7/8 ID x 1-1/4 R/L Nut
RL-SC-1814	Rotalock Straight Connector - 1-1/8 ID x 1-1/4 R/L Nut
RL-SC-1834	Rotalock Straight Connector - 1-1/8 ID x 1-3/4 R/L Nut
RL-SC-1384	Rotalock Straight Connector - 1 3/8 ID x 1 3/4 R/L Nut



NEW

Rotalock Elbow Connector

Part No.	Description
RL-EC-3834	Rotalock Elbow Connector - 3/8 ID x 3/4 R/L Nut
RL-EC-1201	Rotalock Elbow Connector - 1/2 ID x 1 R/L Nut
RL-EC-5801	Rotalock Elbow Connector - 5/8 ID x 1 R/L Nut
RL-EC-5814	Rotalock Elbow Connector - 5/8 ID x 1 1/4 R/L nut
RL-EC-3401	Rotalock Elbow Connector - 3/4D x 1 R/L Nut
RL-EC-7801	Rotalock Elbow Connector - 7/8D x 1 R/L Nut
RL-EC-7814	Rotalock Elbow Connector - 7/8 ID x 1 1/4 R/L Nut
RL-EC-1814	Rotalock Elbow Connector - 1-1/8 ID x 1-1/4 R/L Nut
RL-EC-1834	Rotalock Elbow Connector - 1-1/8 ID x 1-3/4 R/L Nut
RL-EC-5824	Rotalock Elbow connector - 1 5/8 ID x 2 1/4 R/L nut

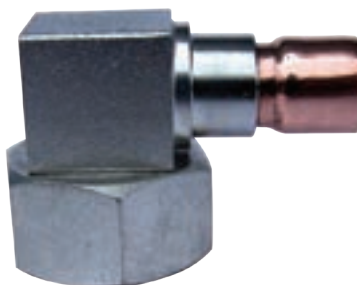

Brass Access Bodies



C&D Valve manufactures brass bodies for a variety of special purposes.

They are stock items and indicate the versatility of our parts. Most have the standard 1/4" male flare above the hex. Below the hex are various threads, outside diameters and inside diameters for accepting different sizes of tubing and connections. Many have multiple steps.

The CD2245 cap and CD4460 valve core are standard with each, except where noted or when the customer specifies differently. ID and OD measurements given are actual part dimensions.

Standard Flare			
Part No.	BAG QTY	Description	
CD1200	6	3/16" ID, 1/4", 5/16" OD steps	
CD2500	6	1/4" ID, 1/4", 5/16" OD steps	
CD2506	6	1/4" ID, 3/8" OD step	
CD3338	6	3/16" ID, 1/4", 3/8" OD steps	
CD3346	6	1/4" ID, 3/8", 7/16" OD steps	
CD3358	6	5/16" ID, 1/2" OD step	
CD3368	6	3/8" ID, 1/2" OD step	
CD4545	6	9/32" ID, 1/4" OD step	
CD5055	6	7/32" ID, 5/16" OD step	
CD9160	6	Flare 9/16" long, hex 7/16" deep, 1/4" OD step	
CD8400	6	1/8" ID, 3/16", 1/4", 5/16" steps, CD2245 cap and core	

Bulkhead			
Part No.	BAG QTY	Description	
CD2243	6	Flare length extended to 3/4", solder end - 1/8" ID, 3/16", 1/4", 5/16" OD steps and CD2217 cap	
CD2576	6	Flare length extended to 5/8", solder end - 1/4" ID, 11/32" OD	
CD3600	6	1/8" ID, 3/16", 1/4", 5/16", steps, 1/8" MPT below hex wrench cap and core	

BV-CRT Ball Valve Core Removal Tools

INSTRUCTIONS

1. Attach the tool to a 1/4" male flare fitting, thumb tight
2. With the valve open, completely push extractor rod in and grab the valve core head
3. Turn the extractor knob counter-clockwise to unscrew the core
4. Pull the extractor knob back as far as possible to close the valve
5. Close the valve completely with a clockwise turn of the handle
6. Remove the rear coupler, extractor rod and valve core. With the valve core removed, the system can be accessed through the rear fitting of the core removal tool, as well as the side port on the CD3930 or CD3910
7. To replace a valve core, attach coupler on extractor rod to rear fitting on tool, thumb tight
8. Open valve completely with counter-clockwise turn of the handle
9. Push extractor rod in and secure valve core in fitting by turning clockwise

KEY FEATURES

- The original CRT has been improved with a ball valve design
- The BV-CRT works the same as our original CRT. It removes a valve core from a 1/4" male flare access fitting without loss of refrigerant. Because it has a ball valve inside rather than a stem-type valve, the tool can be closed with just a quarter turn.

With the valve core out, many operations can be performed including:

- Replacing a bad core
- Adding or removing refrigerant
- Measuring internal temperature (CD3975 required)
- Measuring system pressure by attaching a gauge to the side port of CD3930



Two BV-CRT models from which to choose



Compact size for working in close quarters



More durable with a stainless steel ball and brazed side fitting



Works with existing CRT accessories



More convenient to use

Part No.	BAG QTY	Description
CD3975	1	Internal Temperature Thermometers
CD3916	1	Thread Chaser
CD3915	1	Pick
CD5577	1	Extractor Rod

Part No.	BAG QTY	Description
CD3920	1	BV-CRT for 1/4" flare connections 
CD3930	1	BV-CRT for 1/4" flare connections and has 1/4" male flare side access port 
CD3956	1	BV-CRT for 5/16" flare connections and has 1/4" male flare side access port 

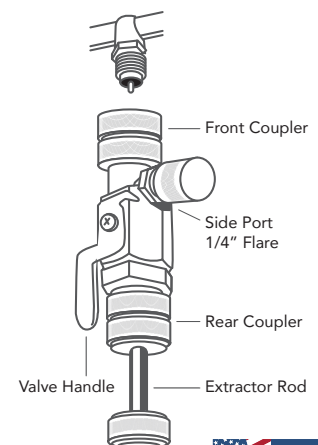

Core Removal Tools



KEY FEATURES







- All accessory tools are compatible with CD3900, CD3910, CD3920, CD3930, and CD3956
- Optional tool for CRT. With any CRT and special access V-Series fitting, a tube can be pierced and a core inserted into V fitting below.
- Tube Piercing Attachment

INSTRUCTIONS

1. Braze V-Series fitting onto line
2. Attach main body of CRT to fitting
3. Attach TPA to the CRT body, screw down needle to pierce hole in tubing until it bottoms out – it will not go through the other side of tube
4. Pull back TPA handle
5. Shut off system with CRT shut off valve
6. Remove TPA from the CRT
7. Attach regular CRT rod with core
8. Open shut-off valve, screw core into V fitting and remove CRT

TECH TIP

Have damaged threads or a broken valve core? Try our CRT thread chaser – available individually or as a kit.

Part No.	BAG QTY	Description	
CD3090	1	Tube piercing attachment punches a hole in copper tubing through a V-Series fitting for the installation of a core without loss of refrigerant	
CD3910	1	Our original 1/4" flare thumb screw shut-off core removal tool – has 1/4" male flare side access port with brass cap	
CD5577	1	Valve core grapple and extractor – removes core without loss of refrigerant	
CD3900	1	Same as the CD3910 except with no side port – Works with all accessories	
CD3916	1	A thread chaser to clean and align the internal threads of an access fitting	
CD3917	1	CD3915 and CD3916 together as a kit	
CD3915	1	A pick to extract a broken core from a housing without loss of refrigerant – has left hand threads	

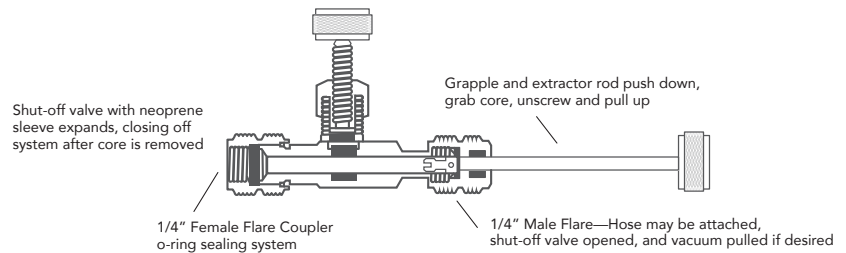

Thermometer

Core Removal Tool Accessory



KEY FEATURES

- LCD read out
- Swivel Head
- On/off switch, hold test switch
- Spare battery
- Temperature range: -58°F (-50°C) to +302°F (150°C)

Description	Part No.	BAG QTY
Thermometer	CD3975	1

Braze-In Service Valves

Core Removal Tool Accessory

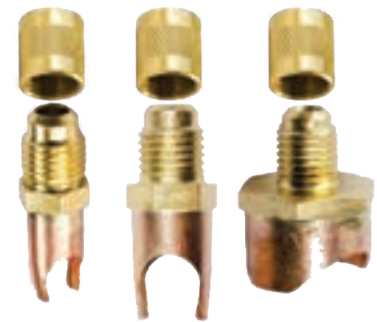

KEY FEATURES

Copper saddle valve for special use with CD3090 Tube Piercing Attachment and any core removal tool. Available to fit nine sizes of copper tubing. These ports are similar to the M Series fittings, but they are internally threaded to house a valve core, and come with a CD2245 cap.

Description	Part No.	BAG QTY
1/4"	CD3094	6
5/16"	CD3096	6
3/8"	CD3098	6
1/2"	CD3092	4
5/8"	CD3095	3
3/4"	CD3034	2
7/8"	CD3078	2
1-1/8"	CD3018	2



Core Depressors

KEY FEATURES

These thumbscrew core depressors are designed to be used on the end of a charging hose. When attached to an access fitting, they can depress the valve core and control the flow of gas. This also means the core can be shut off before disconnecting, thus avoiding a spit back on your hand. The seals in each part have broad compatibility with all refrigerants. The CD2070 is unique in that it has an internal shut-off that also holds gas in the hose when disconnected.

Part No.	BAG QTY	Description	
CD2060	1	For 1/4" Male flares	
CD2050	1	For 3/16" Male flares	
CD2070	1	1/4" Female flare compact thumbscrew core depressor	
CD5050	1	For 1/4" male flares – made small for use in tight quarters	
CD2080	1	5/16" Female flare compact thumbscrew core depressor	
CD5060	1	5/16" Female flare compact thumbscrew core depressor	

Hose-End Ball Valve

KEY FEATURES

Reliable and easy to use, the body of this valve is constructed with the same durable design as our BV-CRT's. Install the CD4040 on the end of a charging hose and minimize refrigerant loss during servicing. A quarter turn of the handle makes quick work of shutting on and off. Straight flow through design offers maximum flow rate. The brass depressor tip fully engages valve core.

Part No.	BAG QTY	Description	
CD4040	1	1/4" Female flare swivel, depressor tip x 1/4" male flare	

Superheat Kits

KEY FEATURES

Superheat Kits combine a Core Removal Tool (CRT) and thermometer to create the most reliable, accurate way to measure superheat.

Attach the CRT to an access fitting and remove the valve core, insert the digital thermometer through the fitting and directly measure the internal temperature.

Measure pressure at the same spot and use this information for determining superheat. The storage case is durable and lightweight; instructions included.



Description	Part No.	BAG QTY
Superheat Kit	CD3970	1

Combines CD3910 and CD3975 thermometer



Description	Part No.	BAG QTY
Superheat Kit	CD3990	1

With CD3930 BV-CRT and CD3975 thermometer

Service Kits

KEY FEATURES

- Handy refillable case with the most commonly used parts
- The right parts in one location
- Highest quality parts made in the USA

Part No.	Description	Case Size
CD9510SVK	Access Fitting Service Kit	8.5 x 4.5"
CD9530SVK	Appliance Service Kit	8.5 x 4.5"
CD9560SVK	Refrigeration Service Kit - 9560	8.5 x 11"
CD9580SVK	Refrigeration Service Kit - 9580	8.5 x 11"



CD9510SVK



CD9530SVK



CD9560SVK



CD9580SVK

Sure Seal™ Retaining Couplers



KEY FEATURES

When attached to an access fitting, the Sure Seal™ Retaining Coupler automatically opens and depresses the valve core all in one action. When disconnected, it traps refrigerant in the charging hose. Leave it permanently installed on the end of the hose. The seals are compatible with newer refrigerants, and if internal parts need replacing, a parts kit is available.

- Premium line of Sure Seal™
- Couplers come in a variety of configurations to handle most applications.
- The CD5171 Sure Seal™ kit contains replacement components reducing the need to buy new couplers.

Part No.	BAG QTY	Description
CD2035	1	1/4" Female flare retainer x 1/4" male flare 
CD2037	1	1/4" Female flare retainer x 3/8" male flare 
CD2084	1	1/4" Female flare retainer x 1/4" MPT 
CD2090	1	90° 1/4" Female flare retainer x 1/4" male flare 
CD2094	1	1/4" Female flare retainer x 1/4" FTP 
CD2098	1	1/4" Female flare retainer x 1/8" FTP 

Adapters / Couplers & Automotive



KEY FEATURES

C&D Valve adapters and couplers are 100% manufactured in the USA with either forged or machining brass. Couplers and adapters can be used in a wide range of applications. Contact Customer Service if you have specific needs for your application.

Part No.	BAG QTY	Description	
CD1414	2	(CD2250 cap) 1/4" flare access x 1/4" MPT	
CC1414	2	(CD2245 cap)	
CD1441	1	1/4" flare access x 1/4" flare, valve core and flare nut included (no cap)	
CD1818	6	(CD2250 cap) 1/4" flare access x 1/8" MPT	
CC1818	6	(CD2245 cap)	
CD1819	3	(CD2250 cap) 1/4" flare access x 1/8" MPT, elbow, 1/4" ID on MPT end	
CC1819	3	(CD2245 cap)	
CD2000	1	1/4" female flare swivel x 1/4" male flare access, depressor tip and seal, no valve core	
CD2010	1	1/4" female flare swivel x 1/4" male flare access, 90° configuration, depressor tip and seal, no valve core	
CD2012	1	1/4" female flare swivel x 1/2" male Acme, depressor tip and seal	







Part No.	BAG QTY	Description	
CD2014	1	1/4" female flare swivel x 1/4" male pipe thread, depressor tip and seal	
CD2018	1	1/4" female flare swivel x 1/8" male pipe thread, depressor tip and seal	
CD2019	1	1/4" female flare swivel x 1/8" female pipe threads, depressor tip and seal	
CD2020	1	1/4" female flare hex x 1/2" male Acme	
CD2022	1	3/8" female flare hex x 1/2" male Acme	
CD2028	1	1/2" Acme female swivel x 1/4" male flare, depressor tip and seal	
CD2041	1	1/4" female flare x 1/4" female pipe threads, depressor tip and seal	
CD2056	1	5/16" female flare x 1/4" male flare adapter	

Part No.	BAG QTY	Description	
CD5013	1	R134a retrofit adapter, straight low side stem (13 mm) x 1/4" female flare, and blue cap	
CD5016	1	R134a retrofit adapter straight high side stem (16 mm) x 1/4" female flare, and red cap	
CD5014	1	Same as CD5036 except for 1/4" male flare	
CD5036	1	1/4" adapter to 3/16" fittings, contains depressor pin	

Blower Wheel Pullers

Fast and easy! A simple method to remove blower wheel from shaft without damage to blower, blower motor or shaft. Unique hub design provides the perfect fit for most blower wheels allowing maximum torque for stubborn hard to remove wheels.



Part No.	BAG QTY	Description
CD3505	1	1-1/4" hub only 
CD3515	1	1-3/8" hub only 
CD3525	1	1-1/2" hub only 
CD3535	1	1-5/8" hub only 
CD3555	3	Set screw 
CD3560	1	5/32" Allen wrench 

Part No.	BAG QTY	Description
CD3570	1	Blower wheel puller kit; contains all sizes
CD3540	1	Drive bolt
CD3545	1	Drive bolt and shank
CD3500	1	Drive bolt, shank and 1-1/4" hub
CD3510	1	Drive bolt, shank and 1-3/8" hub
CD3520	1	Drive bolt, shank and 1-1/2" hub
CD3530	1	Drive bolt, shank and 1-5/8" hub

Fastap™ Tube Piercing Pliers

Part No.	BAG QTY	Description
CD4311	1	Fast refrigerant recovery with pliers that clamp on and pierce tube. Works on tubing sizes from 1/4" to 7/8". Pliers are simple to use and light weight. Piercing tip is self sharpening, but also easily replaceable.
CD4314	1	Replacement piercing tip
CD4315	2	Replacement gaskets for pliers



INSTRUCTIONS

1. Connect service hose to fitting on pliers
2. Size locking pliers to tubing for proper clamping
3. Align tip to center of tubing and clamp down
4. Recover refrigerant

Locking Caps and Keys

REFRIGERANT LOCKING CAP DRIVER

- Your one tool to remove industry standard locking caps
 - 3 bits for access to C&D Valve, Novent and Shield® Cap*
 - Magnetic tip securely holds bits in place
 - Bits stored in handle for convenient access and storage
 - Compact design helps allow access in tight spots
- * Novent is a registered trade mark of the Rector Seal Corporation;
Shield is a registered trademark of JB Industries Inc.

Put safety first with refrigerant locking caps and keys

Need to remove industry standard locking caps? Try our 3-in-1 refrigerant locking driver and eliminate the need to carry three different keys. Locking caps help in the prevention of refrigerant theft, leaks to the environment, and serious injury or death resulting from the inhalation of dangerous refrigerants.



CD3830	1
--------	---

Cap Driver Replacement Bits

Part No.	Description
CD3831	Red - Novent®
CD3832	Green - Novent®
CD3833	Silver - C&D - Shield®

VALVE CORE TORQUE DRIVER

- Calibrated to install standard refrigeration valve cores to 4 to 5 in/ lbs per ARI 720-2002
- Driver has torque “breakaway” feature that disengages the driver when the proper torque is reached—no need to listen for a “click”
- Driver torque in reverse is non-limiting. This allows for as much torque as necessary to remove difficult cores.



CD3815	1
--------	---

LOCKING REFRIGERANT SAFETY CAP KEY FEATURES

- Works with standard valve core key
- Help prevent unauthorized access
- Locks in place to prevent refrigerant loss
- Meets CMC (California Mechanical Code) and Title 24
- 1106.3.1 Refrigerant Service Ports
- Meets IMC 1101.10 and IRC M1411.6

1/4" Locking Caps

Part No.	BAG QTY
CD2290/2	2
CD2290/10	10
CD2290/50	50

5/16" Locking Caps

Part No.	BAG QTY
CD2295/2	2
CD2295/10	10
CD2295/50	50



Oil Tap & Cap Tubes



OIL TAP

The oil tap is installed on a semi-hermetic compressor for the changing of oil and testing procedures. The internal pressure helps discharge the oil from the crankcase and acid tests can be made while the compressor is running. It allows the addition by vacuum or removal by pressure of oil while compressor is running. Detect hazardous refrigerant pooling in the crankcase before start-up and control the removal using a compound gauge. The oil tap can be permanently installed.

CD1808

1

CAP TUBES

Part No.	BAG QTY	Description
CD2540	1	Factory made double flare connection, used in such ways as an external equalizer tube on an expansion valve, 36" of copper tube with double flares on swivel on each end, and no depressor tips
CD2541	1	Same as CD2540, with a depressor tip on one end
CD2542	1	Same as CD2540, with a depressor tip on each end



TECH TIP

Always install a new valve core when finished servicing a system. Installing a new valve core is your best method in preventing access fitting leaks.

CORE CONTAINER | WRENCH

Part No.	BAG QTY	Description
CD3813	1	Core container with wrench, all brass with knurl for easy handling, compact design holds three valve cores
CD3805	10	Plastic tube container with six valve cores and one core wrench tool – only available in a display box of 10

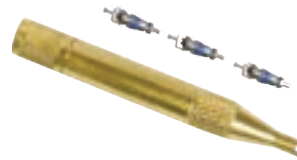

CORE CHASER | WRENCH

Part No.	BAG QTY	Description
CD3800	1	Two (2) tools - a core wrench and thread chaser, comes with six (6) cores and overall length is 3-1/2"



Parts, O-Rings & Replacement Parts

From caps to grommets to valve cores, C&D Valve has all the access fitting replacement parts you need to finish the job. Contact Customer Service for assistance in finding the right component for your job.



Part No.	BAG QTY	Description
CD2210	25	1/4" Flare black glass-filled nylon cap with neoprene o-ring seal
CD2214	6	10 mm - 1.25 black glass-filled nylon cap with neoprene o-ring seal
CD2215	6	1/4" Flare black glass-filled nylon cap with retainer strap and neoprene o-ring seal
CD2217	6	1/4" Flare black glass-filled nylon cap with black retainer strap and neoprene o-ring seal
CD2220	6	1/2" Acme black glass-filled nylon cap with neoprene o-ring seal
CD2225S	6	1/4" Flare flex brass cap, use with M Series line-cap valves or with copper gasket (CD0500) for metal to metal seal
CD2225T	25	1/4" Flare flex brass cap, use with M Series line-cap valves or with copper gasket (CD0500) for metal to metal seal
CD2235	6	1/4" Flare heavy-duty hex brass cap with neoprene o-ring seal
CD2245S	6	1/4" Flare heavy-duty round brass cap with neoprene o-ring seal
CD2245T	24	1/4" Flare heavy-duty round brass cap with neoprene o-ring seal
CD2250S	6	1/4" Flare heavy-duty round brass cap with core wrench tool and neoprene o-ring seal
CD2250T	25	1/4" Flare heavy-duty round brass cap with core wrench tool and neoprene o-ring seal
CD2255	6	1/4" Flare heavy-duty round brass cap with neoprene o-ring seal and security wire
CD2260	6	1/4" Flare heavy-duty round brass cap with neoprene gasket seal
CD2265	6	1/4" Flare round brass cap with neoprene gasket o-ring seal, attached keeper chain to prevent loss of cap



Parts, O-Rings & Replacement Parts

From caps to grommets to valve cores, C&D Valve has all the access fitting replacement parts you need to finish the job. Contact Customer Service for assistance in finding the right component for your job.

Caps		
Part No.	BAG QTY	Description
CD0400	5	1/4" Flare forged nut (short)
CD0500	10	Copper gasket, for use with CD2225 cap
CD2577	6	1/4" Flare hex nut
CD4460S	6	Valve core with PTFE seal, tapered, positive stop barrel
CD4460T	25	Valve core with PTFE seal, tapered, positive stop barrel
CD5038	6	1/2" OD hose grommet for 3/8" charging hoses
CD5161	25	5/16" OD x 5/16" neoprene hose grommet
CD5501	25	PTFE o-ring seals for M Series

O-Rings		
Part No.	BAG QTY	Description
CD0066	10	1/8" ID, 1/4" OD
CD0077	10	5/32" ID, 9/32" OD
CD0099	10	7/32" ID, 11/32" OD
CD0101	10	1/4" ID, 3/8" OD
CD0111	10	5/16" ID, 7/16" OD, CRT, core depressor couplers
CD1050	10	5/32" ID, 11/32" OD
CD1060	10	3/16" ID, 3/8" OD, CD2223, CD2235, CD2250, CD2255 cap
CD1070	10	7/32" ID, 13/32" OD, CD2219, CD2245, CD2265 cap
CD1090	10	5/16" ID, 1/2" OD, CRT, core depressor couplers

Replacement Parts		
Part No.	BAG QTY	Description
CD5555	1	Core Removal Tool: O-rings necessary to repair a CRT except those contained in the chuck
CD5560	1	Core Removal Tool: Shut-off them with molded neoprene gland, includes brass stem, knob, retaining nut and gland
CD5577	1	Core Removal Tool: Brass rod and chuck, rear end sealing coupler and knob all in one piece
CD5171	1	Sure Seal™ Retaining Coupler: Set repair kit containing o-rings, washer, valve depressor and springs



Vibration Eliminator

NEW

C&D Vibration eliminators have been designed and developed to offer the longest service life and easiest installation.

- High grade stainless steel inner convoluted tube and outer support braid.
- Tig welded internals for greater strength.
- Pressed braid retention collars offering increased durability.
- Solid copper connectors.
- Customizing available for OEM's
- Safe working pressure: 650psig
- Certification: UL



Part No.	Description
VE-038	3/8 ID Vibration Eliminator SST with copper tails
VE-012	1/2 ID Vibration Eliminator SST with copper tails
VE-058	5/8 ID Vibration Eliminator SST with copper tails
VE-034	3/4 ID Vibration Eliminator SST with copper tails
VE-078	7/8 ID Vibration Eliminator SST with copper tails

Part No.	Description
VE-118	1 1/8 ID Vibration Eliminator SST with copper tails
VE-138	1 3/8 ID Vibration Eliminator SST with copper tails
VE-158	1 5/8 ID Vibration Eliminator SST with copper tails
VE-218	2 1/8 ID Vibration Eliminator SST with copper tails
VE-258	2 5/8 ID Vibration Eliminator SST with copper tails

Rotalok Teflon Gasket

NEW

High quality virgin Teflon gaskets to suit C&D and most other brands of rotalock valves

Part No.	Description
RL-GSK-034	Rotalok Teflon Gasket - suit 3/4 R/L
RL-GSK-100	Rotalok Teflon Gasket - suit 1 R/L
RL-GSK-114	Rotalok Teflon Gasket - suit 1-1/4 R/L
RL-GSK-134	Rotalok Teflon Gasket - suit 1-3/4 R/L
RL-GSK-214	Rotalok Teflon Gasket - suit 2-1/4 R/L
RL-GSK-5PK	Assorted Rotalock Teflon Gaskets Pack 5



C&D VALVE

part of ASPEN PUMPS GROUP – NORTH AMERICA

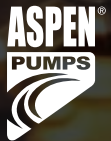

TEKEDGE



cdvalve.com | sales@cdvalve.com | 800-654-9233



REV. 09.24